

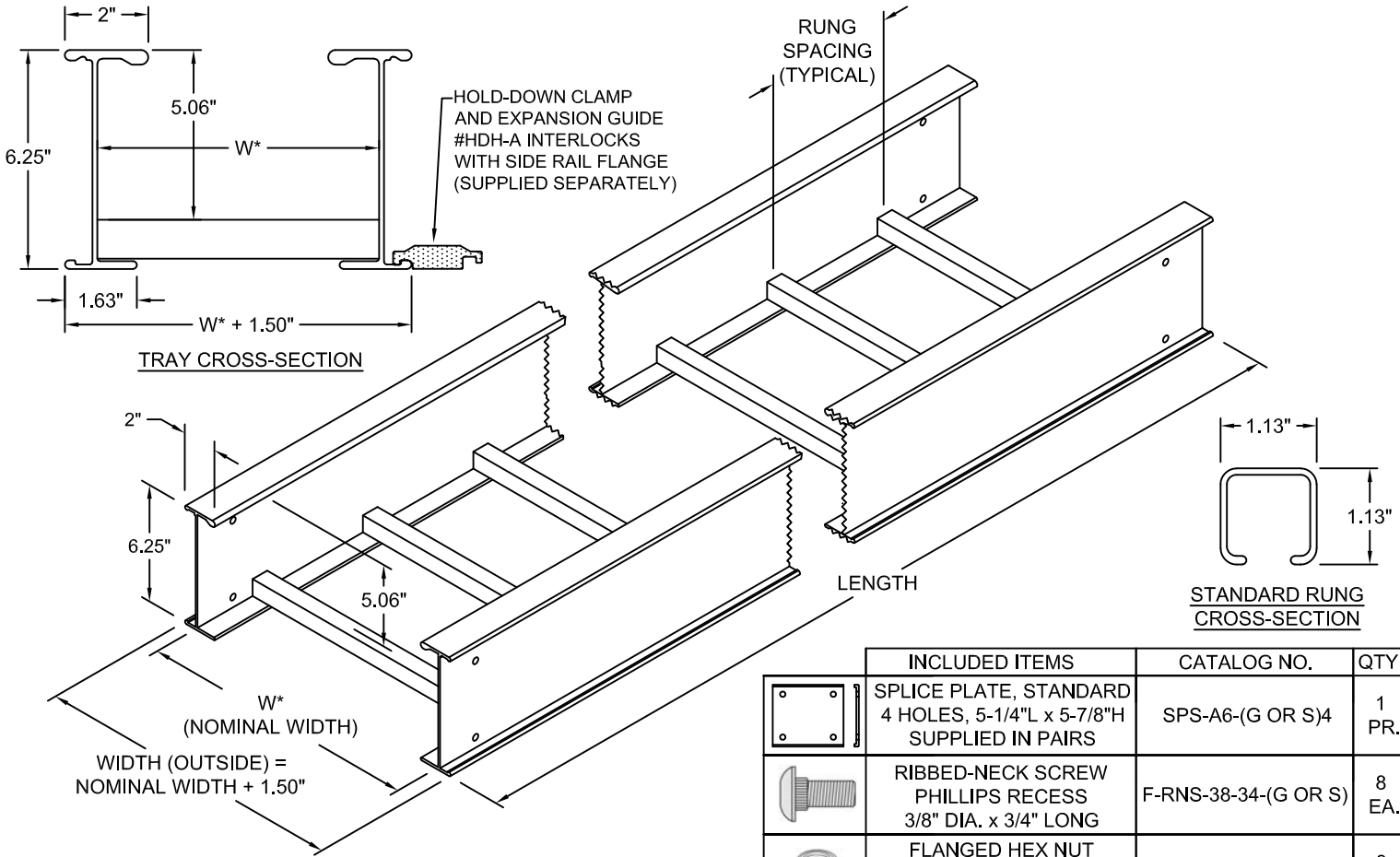

NO.	REVISION	BY	DATE	MATERIAL I.D.
0	APPROVED	TM	03-21-11	A620A-LA
1	ADDED RUNG OPTIONS, HDH-A, REVISED TITLE BLOCK	TM	10-01-15	



	INCLUDED ITEMS	CATALOG NO.	QTY.
	SPLICE PLATE, STANDARD 4 HOLES, 5-1/4"L x 5-7/8"H SUPPLIED IN PAIRS	SPS-A6-(G OR S)4	1 PR.
	RIBBED-NECK SCREW PHILLIPS RECESS 3/8" DIA. x 3/4" LONG	F-RNS-38-34-(G OR S)	8 EA.
	FLANGED HEX NUT 3/8" DIA., SERRATED FACE 9/16" SOCKET SIZE	F-FHN-38-(G OR S)	8 EA.

SPLICE PLATES: NECESSARY SPLICE CONNECTORS AND FASTENERS ARE AUTOMATICALLY SUPPLIED WITH ALL STRAIGHT TRAY SECTIONS AND FITTINGS. FASTENER MATERIALS ARE GEOMET-PLATED STEEL (G) AND TYPE 316 STAINLESS STEEL (S).



CLASSIFIED BY UNDERWRITERS LABORATORIES AS TO IT'S SUITABILITY AS AN EQUIPMENT GROUNDING CONDUCTOR ONLY PER NEC 392. METAL CABLE TRAY IN ACCORDANCE WITH THE STANDARD FOR CABLE TRAY SYSTEMS CANADA CSA-C22.2 NO. 126. (UL FILE NO. E341872)

MATERIAL: EXTRUDED ALUMINUM ALLOY 6063-T6
FINISH: PLAIN (POWDER COATED PAINTS AVAILABLE)
CABLE TRAY TYPE: LADDER, TWO RAILS
LOAD RATING (NEMA): 62 LBS/FT, 20' SPAN, CLASS 20A
LOAD RATING (CSA): 92 KG/M, 6.0 METER SPAN, CLASS D
SIDE RAIL HEIGHT: 6" NOMINAL (6.25" ACTUAL)
INSIDE LOAD DEPTH: 5" NOMINAL (5.06" ACTUAL)
BOTTOM: 1.13" WIDE RUNGS (TUBULAR WITH OPEN SLOT)
CONSTRUCTION: ARC-WELDED ON BOTH SIDES OF RUNGS
MIN. CROSS-SECTIONAL AREA PER NEC 392: 1.50 IN ²
AMPERAGE RATING PER NEC 392: 1,600 AMPERES
TRAY FITTING CLASS: 2 (2.00" WIDE FLANGES)
MOMENT OF INERTIA (EACH SIDE RAIL): 4.720 IN ⁴ (x-x)
SECTION MODULUS (EACH SIDE RAIL): 1.418 IN ³ (x-x)

CATALOG NUMBERS

EXAMPLE: **A620A - 09 (†) - SL20 - 24 - S**

† MARK "†" IN BOX TO INCLUDE IN SUBMITTAL

CABLE TRAY SYSTEM NO.	RUNG SPACING †	ITEM CODE	LENGTH †		WIDTH (W) †		FASTENER MATERIAL †
			10	10'-0"	06	6"	
A620A	06	SL STRAIGHT LENGTH	12	12'-0"	09	9"	G GEOMET PLATED STEEL
	09		20	20'-0"	12	12"	
	12		24	24'-0"	18	18"	S TYPE 316 STAINLESS STEEL
					24	24"	
					30	30"	
					36	36"	

† RUNG TYPE	RUNG AND BOTTOM DESIGN OPTIONS
BLANK	STANDARD 1.13" WIDE TUBULAR RUNG
	OPTIONAL RUNG OR BOTTOM DESIGN AS SHOWN ON DRAWING USP-AL-RB-2

CUSTOM TRAY LENGTHS AND WIDTHS ARE AVAILABLE; CONSULT FACTORY.



United Structural Products, LLC
 560 WHARTON CIRCLE, SUITE E PHOENIX: 404-696-8585
 ATLANTA, GA 30336 USA FAX: 404-696-8599

SHEET NO. 1 OF 1
DIMENSIONS INCHES

THIS CABLE TRAY SYSTEM IS IN FULL COMPLIANCE WITH ALL ASPECTS OF THE LATEST REVISIONS OF NEMA STANDARD VE1, CSA C22.2 NO. 126 AND NATIONAL ELECTRICAL CODE ART. 392.

DESCRIPTION CABLE TRAY STRAIGHT SECTION, LADDER, ALUM. 6" HIGH, CLASS 20A
DRAWING NUMBER USP-A620A-LA-SL20



NO.	REVISION	BY	DATE	MATERIAL I.D.
0	APPROVED	TM	03-06-11	A620A-LC
1	ADDED CALCULATIONS FOR 8' SPAN	TM	06-15-11	
2	REVISED TITLE BLOCK AND NOTES	TM	10-01-15	

SAFE LOAD AND DEFLECTION OF CABLE TRAY SIDE RAILS ALUMINUM CABLE TRAY SYSTEM A620A

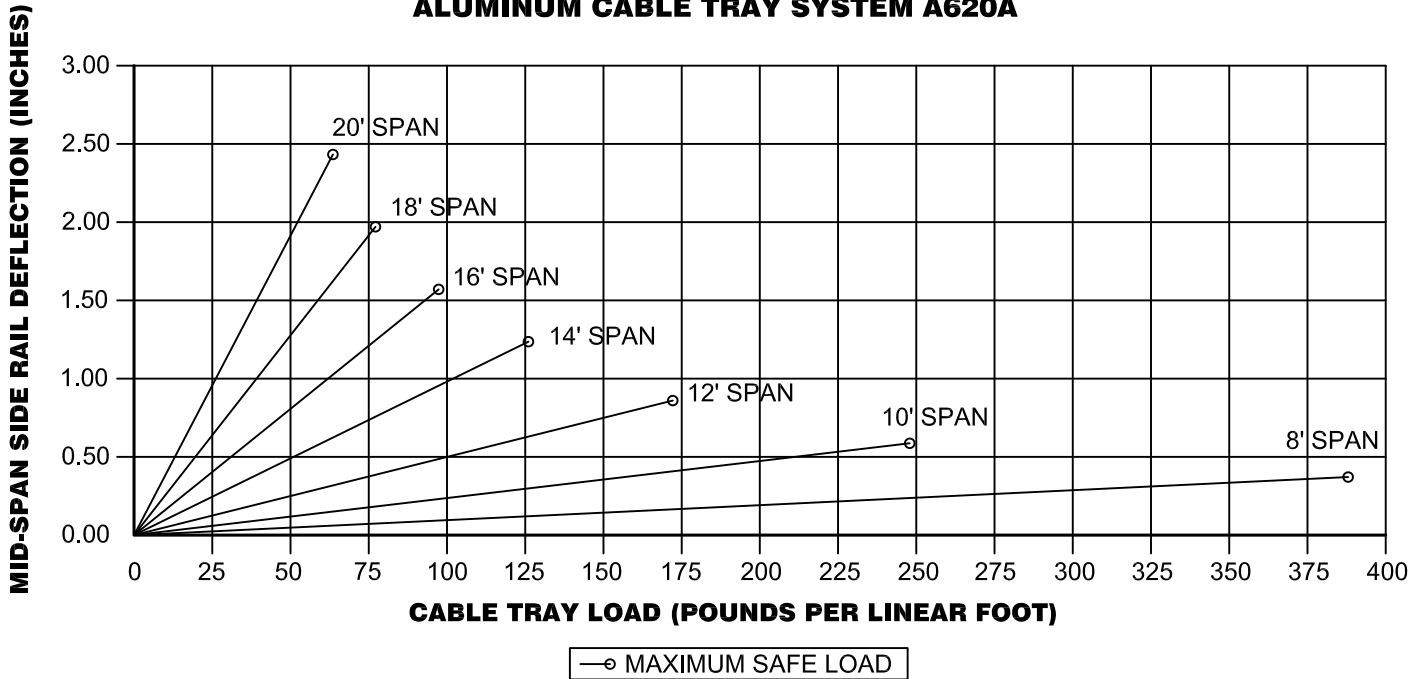

TRAY SYSTEM	SAFETY FACTOR	TRAY SAFE LOAD DATA TESTED PER NEMA VE-1	SUPPORT SPAN (FEET)						
			8	10	12	14	16	18	20
A620A	1.5	MAX. SAFE LOAD (LBS/FT)	387	248	172	126	96	77	62
		DEFLECTION (INCHES)	0.39	0.61	0.88	1.20	1.56	1.98	2.44
		DEFLECTION MULTIPLIER	0.00101	0.00246	0.00512	0.00949	0.01620	0.02567	0.03935

SAFETY FACTOR	RUNG SAFE LOAD LIMITS, TESTED PER NEMA VE-1 SECTION 5.4	TRAY WIDTH (INCHES)						
		6	9	12	18	24	30	36
1.5	MAX. SAFE LOAD (LBS, UNIFORM)	2400	1600	1200	800	600	778	649
	MAX. SAFE LOAD (LBS, CONCENTRATED)	1200	800	600	400	300	389	324

1. THIS DATA APPLIES TO ALL LADDER, VENTED/TROUGH, AND FLAT-SHEET SOLID BOTTOM CABLE TRAYS THAT EMPLOY SIDE RAIL SYSTEM A620A. ALL OF THESE TRAY TYPES ARE CONSTRUCTED WITH RUNGS.
2. DATA IS BASED ON SIMPLE-BEAM TYPE SUPPORTS WITH EVENLY DISTRIBUTED LOADS.
3. MAXIMUM SAFE LOAD IS BASED ON A SAFETY FACTOR OF 1.5 APPLIED TO COLLAPSE.
4. WHEN SUPPORTED ON MULTIPLE-SPAN ARRANGEMENTS, ACTUAL DEFLECTION WILL BE UP TO 60% LESS THAN THE SIMPLE-BEAM DEFLECTION SHOWN.
5. ALL LOAD TESTS WERE CONDUCTED IN ACCORDANCE WITH NEMA STD. VE1, CSA C22.2 NO. 126. 36" WIDE TRAYS WERE TESTED ON 20'-0" SUPPORT SPANS. DATA SHOWN FOR SPANS LESS THAN 20' ARE EXTRAPOLATED PER NEMA VE1. DETAILED TEST REPORTS ARE AVAILABLE UPON REQUEST; CONTACT ENGINEERING DEPT.
6. MULTIPLY THE DEFLECTION MULTIPLIER BY THE ACTUAL LOAD (LBS/FT) TO CALCULATE THE DEFLECTION (INCHES) AT LOADS LESS THAN THE MAXIMUM SAFE LOAD.
7. THIS TRAY SYSTEM WILL SUPPORT A 200 POUND CONCENTRATED STATIC LOAD APPLIED AT THE CENTER OF ANY RUNG, IN ADDITION TO THE FULL SAFE CABLE LOAD, WITHOUT FAILURE OF THE RUNG OR THE SIDE RAILS.



THE LOAD AND DEFLECTION DATA OF THIS CABLE TRAY SYSTEM IS BASED ON DESTRUCTION LOAD TESTS PER NEMA VE1, CSA C22.2 NO. 126 THAT WERE WITNESSED AND CERTIFIED ACCURATE BY UNDERWRITERS LABORATORIES, INC.



United Structural Products, LLC

560 WHARTON CIRCLE, SUITE E PHONE: 404-696-8585
ATLANTA, GA 30336 USA FAX: 404-696-8599

SHEET NO.	1 OF 1
DIMENSIONS	INCHES

DESCRIPTION
LOADING DATA FOR CABLE TRAY SYSTEMS A620A

DRAWING NUMBER
USP-A620A-LDATA15-20